

Inserta Products, Inc.

CHECK VALVES SLIP-IN TYPE

INSERTA® ICS Check Valves, Slip-In Type, can be inserted in manifolds, subplates, flanges or integrated valve systems. This compact design eliminates external leak points associated with line mounted check valves. These check valves can control flow in or out depending on how they are inserted into the machined cavity.

These disc check valves are also available with a fixed orifice for customers' specific quantity requirement.

INSERTA® ICS Check Valves, Slip-In Type, are all steel construction with hardened, lapped discs and seats providing positive fluid shut off. They come complete with O-rings.

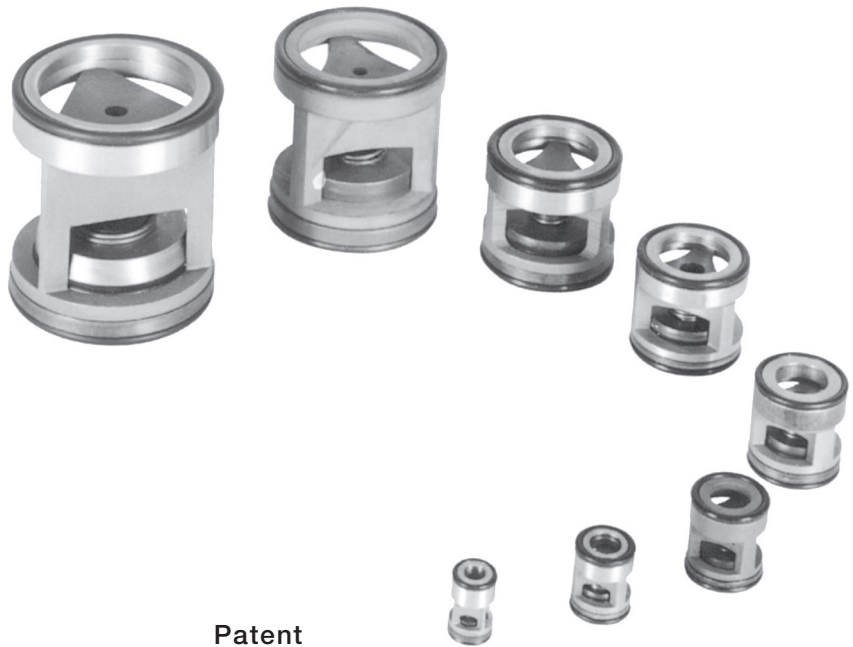

Patent
5,010,916

ORDERING INFORMATION

INSERTA®
CHECK VALVES
SLIP-IN TYPE

DESIGN CODE

B = FOR NOMINAL SIZE 02
C = FOR NOMINAL SIZE 04,06,12
D = FOR NOMINAL SIZE 08,16,20,24,32,40,48

NOMINAL SIZE

02 = 1/8	20 = 1 1/4
04 = 1/4	24 = 1 1/2
06 = 3/8	32 = 2
08 = 1/2	40 = 2 1/2
12 = 3/4	48 = 3
16 = 1	

ICS-D-24-N015-RØ

FLOW CONTROL OPTION

R = FIXED RESTRICTIVE ORIFICE
Ø = DIAMETER (INCH) OF THE FIXED ORIFICE. CUSTOMER MUST SPECIFY THE ORIFICE DIAMETER.
SEE "RØ" ON DATA SHEET FOR MAX. ORIFICE DATA. (MIN. Ø = .016)
(OMIT FOR STANDARD CHECK VALVE)

CRACKING PRESSURE

003 = 3 PSI	} Optional Longer Check Valve
007 = 7 PSI	
015 = 15 PSI (STANDARD)	
030 = 30 PSI	
060 = 60 PSI	
090 = 90 PSI	

SEAL COMPOUND

N = BUNA-N (STANDARD)
V = VITON

Inserta Products, Inc.
Blue Bell, Pa. 19422

CHECK VALVES
SLIP-IN TYPE



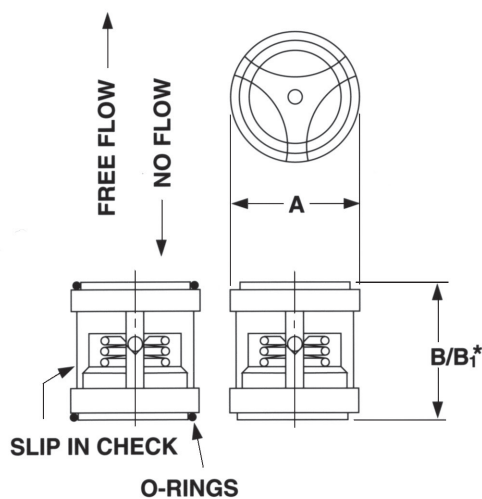

VALVE SIZE	NOMINAL FLOW (GPM)	A -.002	B -.002	B1* -.002	RO MAX	O-RING SIZE NO. (MM) DESIGN CODE C	O-RING SIZE NO. (MM) DESIGN CODE D
02	2	.333	.531	.728	.024	(6.2 X 1.0)	N/A
04	5	.451	.571	.846	.039	(8.5 X 1.5)	(8.0 X 1.8)
06	10	.589	.669	.866	.078	(12.0 X 1.5)	(11.2 X 1.8)
08	18	.746	.787	.945	.078	(16.0 X 1.5)	016
12	24	.963	.906	1.220	.140	116	N/A
16	45	1.199	1.102	2.434	.218	213	213
20	75	1.553	1.653	2.500	.275	219	218
24	110	1.770	2.007	2.500	.394	222	222
32	200	2.391	2.858	3.582	.394	227	227
40	300	2.883	3.407	3.532	.394	231	230
48	400	3.385	3.507	4.119	.394	235	234

NOTE: MINIMUM ORIFICE=.016 DIAMETER

In applications where the valve is subject to sudden shock opening or closing (e.g. Accumulator System), the nominal rated flow must not be exceeded and a minimum cracking pressure of 15 PSI is required.

MACHINED CAVITY DIMENSIONS
SURFACE FINISH TO BE 63

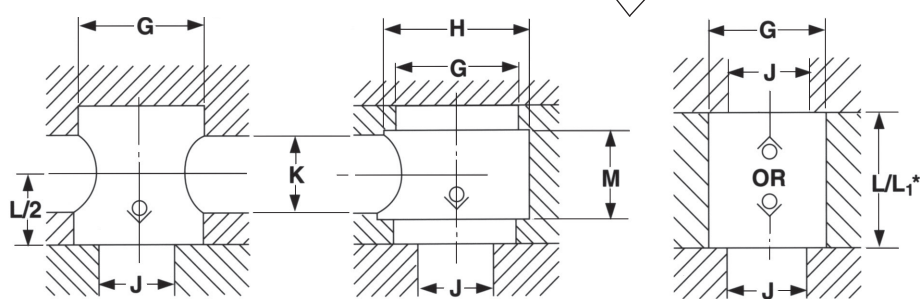

TEE BRANCH RIGHT ANGLE STRAIGHT THRU
(COMBINATIONS OF THESE CAVITIES CAN BE USED)

NOMINAL FLOW RATES
ARE WITH A ΔP OF
20 TO 40 PSI

CAUTION
Care must be exercised when installing check valve to insure the free flow path of the slip-in check valve is correct for the system in which it is installed.

VALVE SIZE	G	H MAX.	J MAX.	K MAX.	L +.002 -.000	L1* +.002 -.000	M MAX.
02	.3346 / .3360	.433	.157	.197	.531	.728	.220
04	.4428 / .4545	.551	.236	.236	.571	.846	.256
06	.5906 / .5923	.709	.315	.354	.669	.866	.374
08	.7480 / .7500	.866	.433	.433	.787	.945	.453
12	.9646 / .9666	1.102	.551	.551	.7906	1.220	.571
16	1.2008 / 1.2032	1.378	.787	.787	1.102	1.535	.787
20	1.5551 / 1.5575	1.811	1.102	1.102	1.653	2.434	1.102
24	1.7717 / 1.7741	2.204	1.250	1.250	2.007	2.500	1.375
32	2.3927 / 2.3960	2.968	1.750	1.750	2.858	3.582	1.875
40	2.884 / 2.887	3.546	2.062	2.062	3.407	3.532	1.750
48	3.386 / 3.389	4.205	2.500	2.500	3.507	4.119	2.000

MOUNTING POSITION:
OPTIONAL
MAXIMUM OPERATING PRESSURE:
5000 PSI (Contact the Factory for pressures up to 7250 PSI)
TEMPERATURE RANGE:
-22°F (-30°C) TO 175°F (80°C)
OPERATING MEDIUM: HYDRAULIC FLUID

VISCOSITY RANGE:
50 SSU TO 2000 SSU
CRACKING PRESSURE:
3 PSI, 7 PSI, 15 PSI (STANDARD)
OR 30 PSI.
* 60 PSI & 90 PSI, OPTIONAL WITH LONGER CHECK VALVE.

Inserta Products, Inc.
Blue Bell, Pa. 19422

CHECK VALVES
SLIP-IN TYPE

