



ADACONN®

ADAFLANGE™ ADAPTERS UNIFIED CODE U61 4-BOLT FLANGE TYPE

The **ADAFLANGE™ ADAPTERS, UNIFIED CODE U61 4-Bolt** Flange Type, have the same bolt mounting patterns as the Code 61. They provide the means to adapt from the Code 61 flange-mounting pattern to the 37° Male Flare. However, they have smaller flange widths than the Code 61 or Code 62 4-Bolt split flanges. They are assembled using industry standard socket head cap screws that meet or exceed the strength requirements of ASTM Standard A574, i.e. minimum tensile of 180,000 PSI. When these are connected to **INSERTA® Unified Code U61 4-Bolt Modular Connectors**, they offer the opportunity to make smaller assemblies and qualify them in specific higher pressure machine applications.

The flat clamp seal flange faces of these adapters fastened with socket head cap screws (SHCS) also makes them ideal for retaining other **INSERTA® Modules**.

These **ADAFLANGE™ ADAPTERS, UNIFIED CODE U61 4-Bolt**, Flange Type, are also available with end configurations to adapt to other tube, pipe or hose connections for specific customers' production requirements.

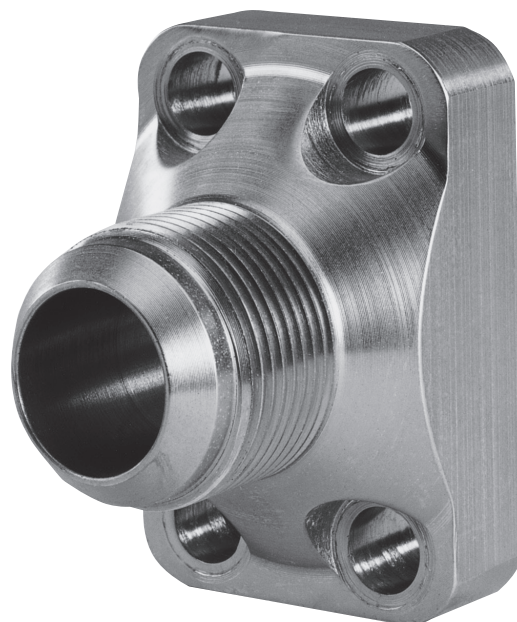

Patent #6,715,798

ORDERING INFORMATION

AFO – UK4 16 – F 16 – 2.25 – S 1 – B

ADACONN®
ADAPTER TYPE
AFO = ADAFLANGE™

DESIGN
UK4 = UNIFIED CODE 61
4-BOLT MOUNTING PATTERN

FLANGE SIZE
02 = 1/8 08 = 1/2 20 = 1-1/4
04 = 1/4 12 = 3/4 24 = 1-1/2
06 = 3/8 16 = 1 32 = 2

MALE THREAD TYPE
F = 37° FLARE

MALE THREAD SIZE
02 = 5/16 – 24 06 = 9/16 – 18 14 = 1 3/16 – 12 32 = 2 1/2 – 12
03 = 3/8 – 24 08 = 3/4 – 16 16 = 1 5/16 – 12
04 = 7/16 – 20 10 = 7/8 – 14 20 = 1 5/8 – 12
05 = 1/2 – 20 12 = 1 1/16 – 12 24 = 1 7/8 – 12

SEAL MATERIAL
B = BUNA N
V = VITON

SURFACE FINISH
1 = ZINC CHROMATE

ADAPTER MATERIAL
S = STEEL

ADAPTER LENGTH
2.25 = THE ACTUAL LENGTH IN
INCHES REF. "L" DIMENSIONS.

ADACONN®
Blue Bell, Pa. 19422

ADAFLANGE™ ADAPTERS
UNIFIED CODE U61 4-BOLT
FLANGE TYPE

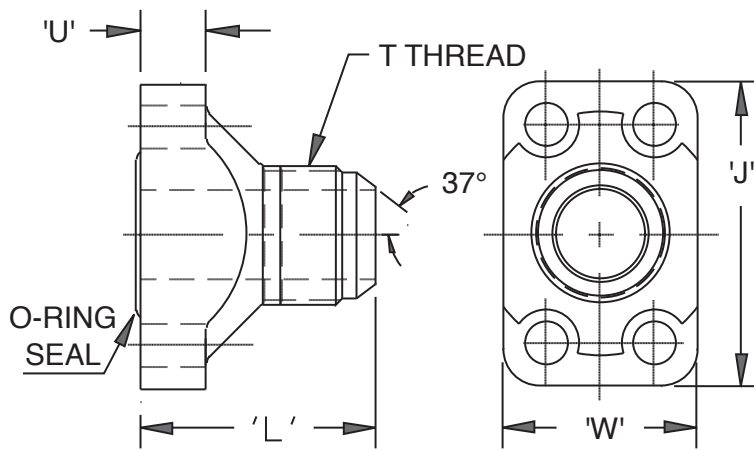

ADAFLANGE™ ADAPTERS, UNIFIED CODE U61 4-BOLT

FLANGE SIZE	NOMINAL SIZE	J	L	T THREAD	U	W	SOCKET HEAD BOLT KIT (4-BOLTS)	O-RING SIZE NO.	BOLT TORQUE IN LBS.
02	1/8	1.00	1.03	5/16-24	.26	.62	ABK-SH4008-32x0.50	010	40/50
02	1/8	1.00	1.03	3/8-24	.26	.62	ABK-SH4008-32x0.50	010	40/50
04	1/4	1.25	1.19	7/16-20	.33	.75	ABK-SH4010-24x0.63	011	60/75
04	1/4	1.25	1.19	1/2-20	.33	.75	ABK-SH4010-24x0.63	011	60/75
06	3/8	1.50	1.38	9/16-18	.40	.87	ABK-SH4025-20x0.87	014	150/170
06	3/8	1.50	1.38	3/4-16	.40	.87	ABK-SH4025-20x0.87	014	150/170
08	1/2	2.12	1.75	3/4-16	.50	1.31	ABK-SH4031-18x1.00	210	250/300
08	1/2	2.12	1.80	7/8-14	.50	1.31	ABK-SH4031-18x1.00	210	250/300
12	3/4	2.56	2.12	3/4-16	.56	1.62	ABK-SH4038-16x1.25	214	400/550
12	3/4	2.56	2.12	1 1/16-12	.56	1.62	ABK-SH4038-16x1.25	214	400/550
12	3/4	2.56	2.12	1 3/16-12	.56	1.62	ABK-SH4038-16x1.25	214	400/550
12	3/4	2.56	2.12	1 5/16-12	.56	1.62	ABK-SH4038-16x1.25	214	400/550
16	1	2.75	2.25	1 1/16-12	.63	1.87	ABK-SH4038-16x1.25	219	500/600
16	1	2.75	2.25	1 5/16-12	.63	1.87	ABK-SH4038-16x1.25	219	500/600
16	1	2.75	2.25	1 5/8-12	.63	1.87	ABK-SH4038-16x1.25	219	500/600
20	1 1/4	3.12	2.31	1 5/16-12	.66	2.12	ABK-SH4044-14x1.50	222	750/900
20	1 1/4	3.12	2.31	1 5/8-12	.66	2.12	ABK-SH4044-14x1.50	222	750/900
20	1 1/4	3.12	2.31	1 7/8-12	.66	2.12	ABK-SH4044-14x1.50	222	750/900
24	1 1/2	3.69	2.56	1 5/16-12	.66	2.50	ABK-SH4050-13x1.50	225	1400/1600
24	1 1/2	3.69	2.56	1 5/8-12	.66	2.50	ABK-SH4050-13x1.50	225	1400/1600
24	1 1/2	3.69	2.56	1 7/8-12	.66	2.50	ABK-SH4050-13x1.50	225	1400/1600
32	2	4.00	2.68	1 5/8-12	.66	3.00	ABK-SH4050-13x1.50	228	2400/2600
32	2	4.00	2.68	1 7/8-12	.66	3.00	ABK-SH4050-13x1.50	228	2400/2600
32	2	4.00	2.68	2 1/2-12	.66	3.00	ABK-SH4050-13x1.50	228	2400/2600

The Unified Code U61 4 & 2-Bolt Flange Port dimensions are listed on page 76.

The bolt kits listed are for mounting the adapters directly to the corresponding port face. The length of the bolts in the kit are indicated after the x; i.e. 1.25 is 1.25 inches long. The length in these bolt kits is the minimum length required to connect to an **INSERTA**® Unified U461 Series steel module and provides 1 1/2 times the nominal bolt diameter for thread engagement. Longer lengths need to be used when other conditions exist such as connecting to lower strength materials. When one wants to use **INSERTA**® components between the port face and these adapters, longer bolts will also be required. Changing the last digits to reflect the length required in inches specifies these longer bolt kits. Bolt kit ordering information is provided in this catalog on page 75.

These bolt kits include industry standard 1960 series bolts (Socket Head Cap Screws) that meet the strength requirements of ASTM Standard A574, i.e. minimum tensile of 180,000 PSI.

ADACONN® Blue Bell, Pa. 19422	ADAFLANGE™ ADAPTERS UNIFIED CODE U61 4-BOLT FLANGE TYPE
---	--